

# LEGEND **FLEET SOLUTIONS**

## INSTALLATION GUIDE FOR VAN EQUIPMENT ON ULTRAGRIP and ULTRAFLOOR

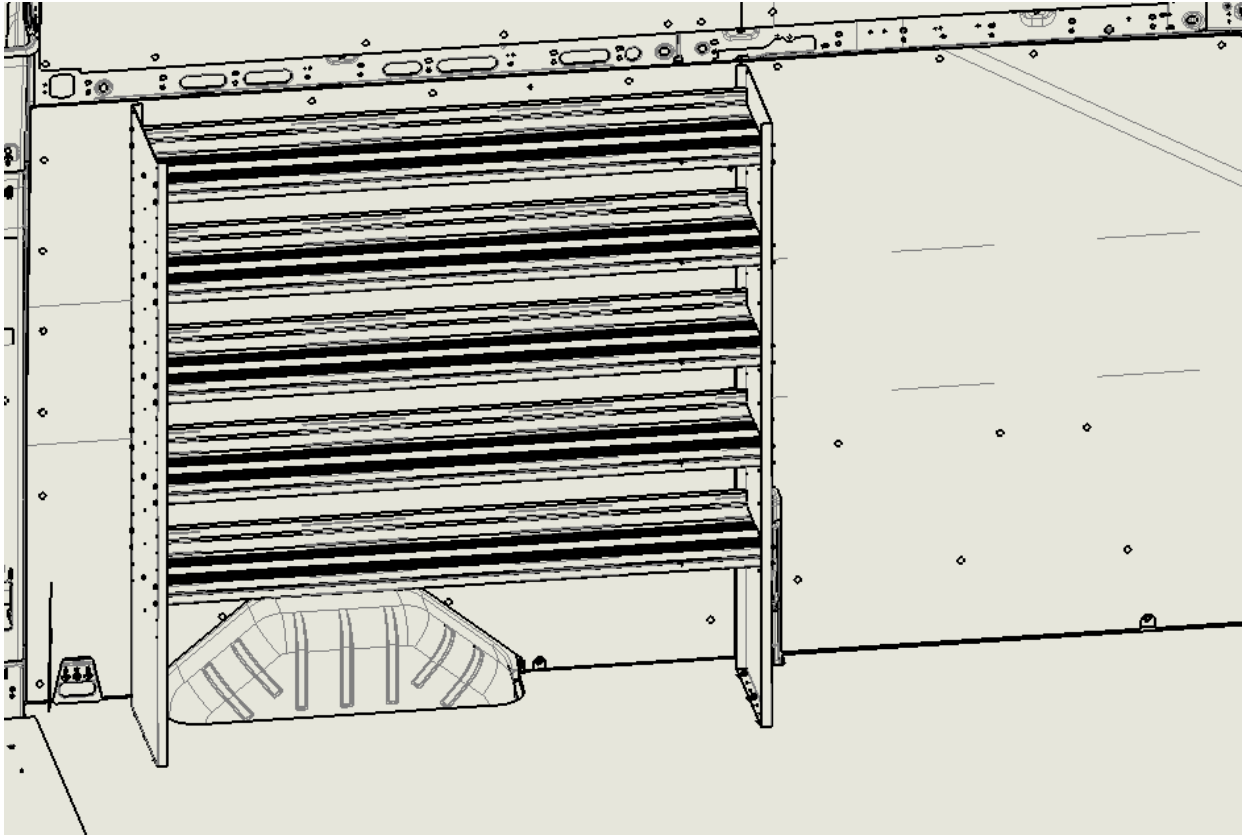

## VAN EQUIPMENT INSTALLATION ON ULTRAGRIP AND ULTRAFLOOR



The plastic floors expand and contract depending on what the temperature is in the environment, the floors must Not be clamped down and prevent this expansion and contraction from happening, the floor must float at all times, if not, it may become wavy and bumpy which will be very uncomfortable and a trip hazard for your customer.

Next are the instructions on how to install all equipment Units on UltraGrip and UltraFloor rigid floors.

## INSTALLATION PROCEDURE

1: Locate the Unit in the desired position.

**NOTE;** make sure the holes you are about to drill do not fall over any gas lines, gas tank or electrical wiring.

- Select all the holes you will be using on the Unit to bolt the Unit down. Using a punch and a hammer; mark these holes on the plastic floor.
- Make sure that all of the holes will be drilled on a flat surface on the vehicle floor, this is important so that the spacers used will sit flat on the floor surface for proper clamping of the Unit as well as keeping the floor floating and free to expand and contract.
- Move the Unit out of the working area.
- Drill a  $\frac{1}{4}$ " pilot hole in all of the marked locations selected.

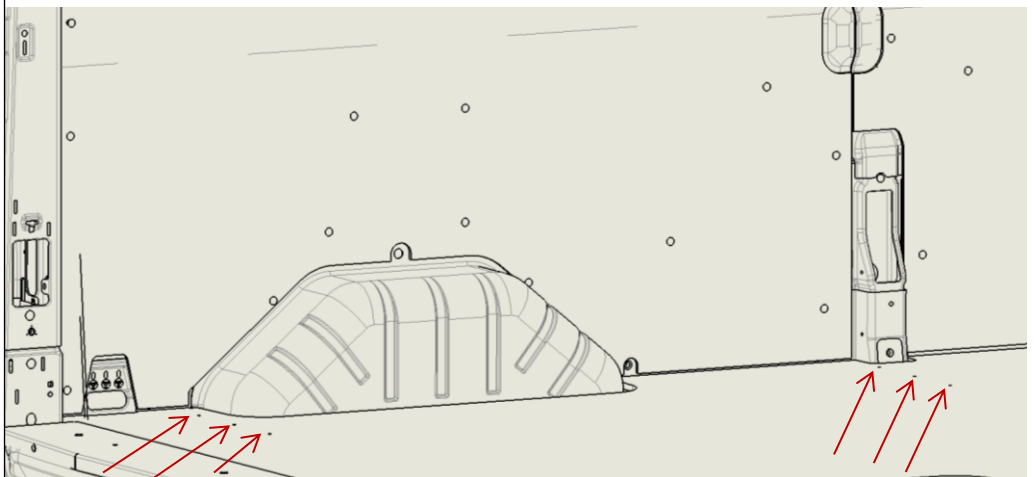
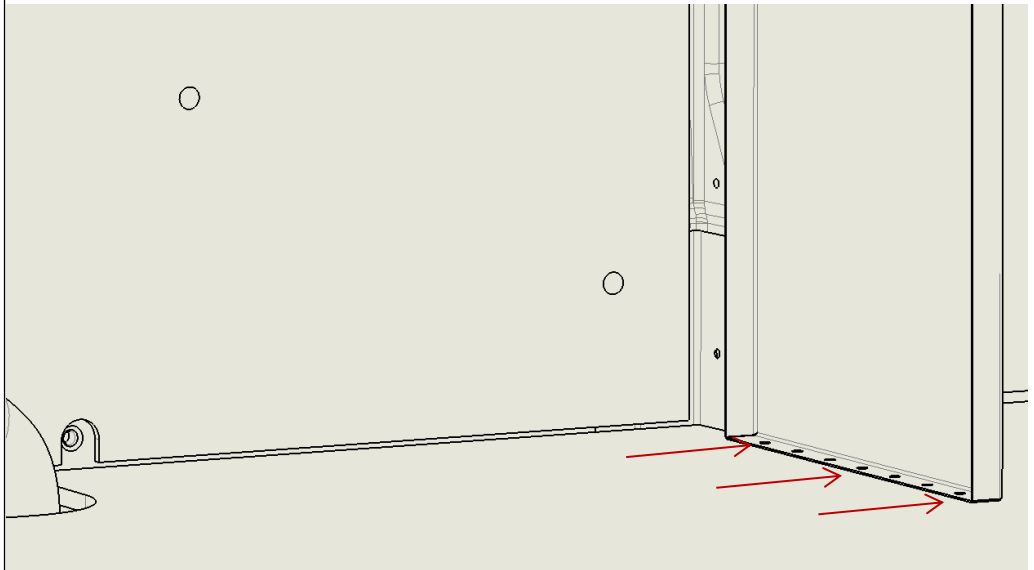
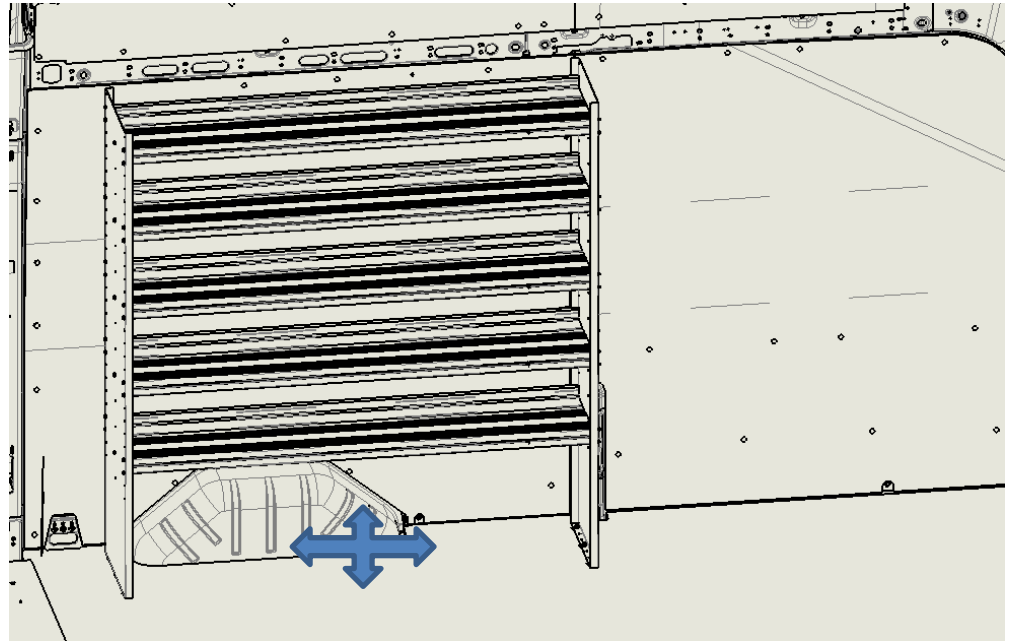

## INSTALLATION PROCEDURE

- In order for the floor to float, all of the Units must be installed on spacers and should not touch the floor.
- The spacers must be thicker than  $\frac{1}{2}$ " which is the floor thickness and they should be as wide as the flange of the panel that it is supporting.

**NOTE;** More than one spacer may be required on an individual hole, depending on where the hole falls on the floor such as between two floor ribs.

- If you are using circular spacers, you must cut holes in the floor that will be  $\frac{1}{2}$ " diameter larger than the Spacers diameter, use a Hole Saw to cut all the holes in the floor.

- If you are using rectangular spacers, the rectangular holes in the floor must be cut  $\frac{1}{2}$ " larger on the width and  $\frac{1}{2}$ " larger on the length.

Use a jigsaw to cut the holes in the floor.

- This will leave  $\frac{1}{4}$ " space all around the spacers for the floor to expand and contract without any issues.

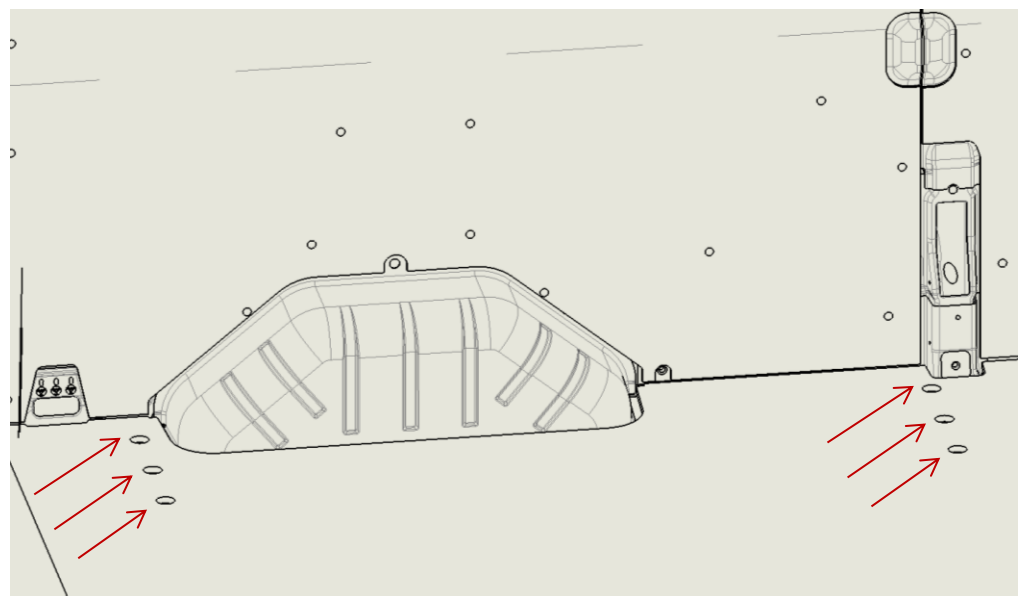
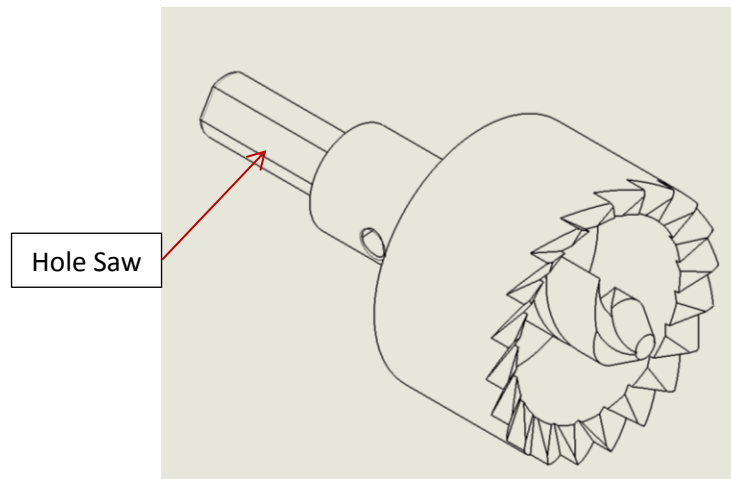
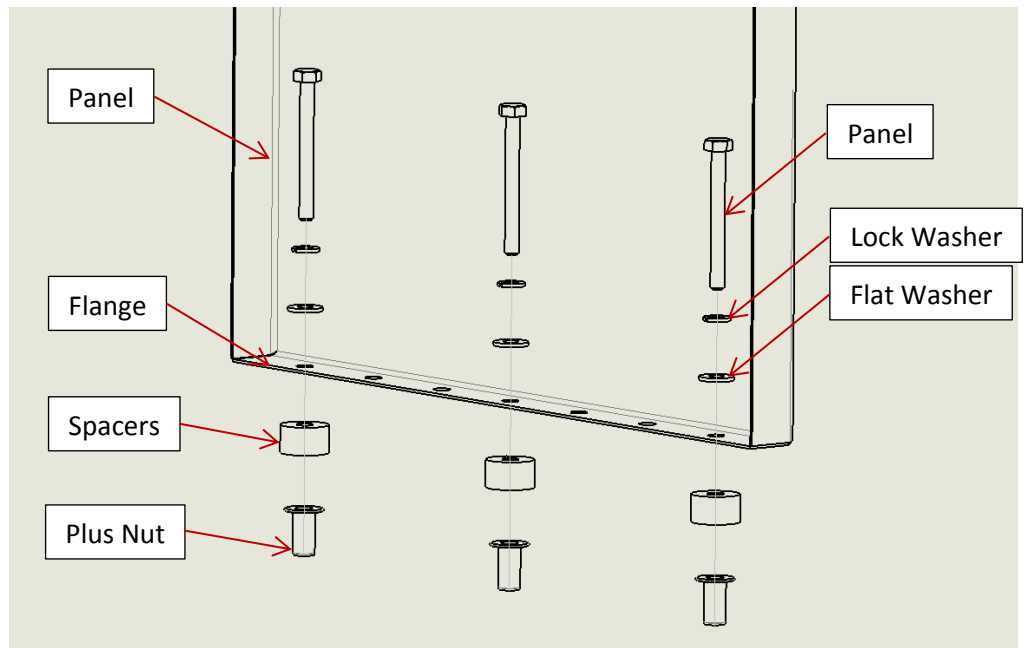

## INSTALLATION PROCEDURE

- If you are using Plus Nuts, you must first drill the pilot holes on the vehicle floor to the size diameter required for the Plus Nuts. Once all the holes are drilled install the Plus Nuts in all of the drilled holes on the vehicle floor.
- If you are using standards Hex nuts, you must drill the pilot holes on the vehicle floor to the size diameter required for the bolt size being used.
- Insert the Spacers into all of the holes in the floor; **make sure that there are enough spacers in each hole to prevent the Unit from touching and clamping down the floor.** Align the Unit holes with the holes in the floor and spacers, pass the bolts with the washers through the Unit flange holes and the spacer through the floor and bolt them down to the plus nut or Hex nut.

**Note; Leave the bolts loose until all of the bolts have been installed. Tighten them all once done.**

Your Unit is now installed and firmly clamped to the vehicle floor and the plastic floor is free to expand and contract without any issues.

